



**APPROVALS**



 **ENGINEERING CODE**  
923HA04

 **APPROVED REFRIGERANT**  
R-404A

 **POWER SUPPLY**  
220-240 V 50 Hz

 **STANDARD CONDITIONS**  
ASHRAE

 **APPLICATION**  
LBP

 **COOLING CAPACITY**  
980 W (LBP)

 **EFFICIENCY**  
1.34 W/W (LBP)

 **MOTOR TYPE**  
CSCR

 **STARTING TORQUE**  
HST

DATA

**General Data**

Type	Hermetic reciprocating
Technology Type	On-Off
Displacement	20.44 cm <sup>3</sup>
Compressor Cooling	Fan/NotControlled/220
Fan Air Flow	520 m <sup>3</sup> /h
Expansion Device	Capillary Tube or Expansion Valve
Horse Power	1 hp
Max Condensing Pressure Operating	24.71 bar
Max Condensing Pressure Peak	27.71 bar
Power Supply	220-240 V 50 Hz
Evaporating Temperature Range	-40 °C to -10 °C

**Electrical Data**

Motor type	CSCR
Starting Torque	HST
Start Winding Resistance	8.4 Ω at 25° C
Run Winding Resistance	1.9 Ω at 25° C

## Mechanical Data

Maximum Recommended Refrigerant Charge	800 g
Oil Charge	450 ml
Oil Type Configuration	ESTER
Oil Type Viscosity	ISO22
Pressurization	Dry air charge
Weight	17.4 Kg
Free Internal Volume	3.3 L

## Electrical Components

	Description
CSR / CSIR Box	YES
Start Capacitor	130-156 Uf / 330 V
Run Capacitor	17.5
Starting Device	RVA403C-123
Motor Protection	MRT26AKK-3261

## External Characteristics

Base Plate	Universal	
Tray Holder	No	
Height	234 mm	
Connector	Internal Diameter	Shape
Suction	9.6 mm	Vertical/Copper
Discharge	6.42 mm	Vertical/Copper
Process	6.42 mm	Vertical/Copper

## PERFORMANCE

## Rated Points

Condensing Temperature	Evaporating Temperature	Cooling Capacity	Power Consumption	Gas Flow Rate	Efficiency
54.40°C	-23.30°C	980 W	732 W	22.69 kg/h	1.34 W/W

Test Condition: ASHRAELBP32, Fan/NotControlled/220, Return Gas 32.2°C, Evaporation -23.30°C, Condensing 54.40°C, Ambient 32.2°C, Liquid 32.2°C, Subcooling 22.2K. Data are an indication of performance based simulation.

## Performance Curve Data

### Condensing Temperature 35°C

Evaporating Temperature °C	Cooling Capacity W	Power W	Gas Flow Rate kg/h	Efficiency W/W
-40	462	438	10.59	1.05
-35	614	502	14.12	1.22
-30	809	564	18.68	1.44
-25	1047	624	24.27	1.68
-20	1326	687	30.91	1.93
-15	1647	754	38.62	2.19
-10	2009	827	47.43	2.43

Test Condition: ASHRAELBP32, Fan/NotControlled/220, Return Gas 32.2°C, Ambient 32.2°C, Liquid 32.2°C. Data are an indication of performance based simulation.

### Condensing Temperature 45°C

Evaporating Temperature °C	Cooling Capacity W	Power W	Gas Flow Rate kg/h	Efficiency W/W
-35	570	511	13.10	1.12
-30	759	589	17.49	1.29
-25	987	668	22.83	1.48
-20	1253	747	29.15	1.68
-15	1558	831	36.45	1.87
-10	1899	921	44.75	2.06

Test Condition: ASHRAELBP32, Fan/NotControlled/220, Return Gas 32.2°C, Ambient 32.2°C, Liquid 32.2°C. Data are an indication of performance based simulation.

### Condensing Temperature 55°C

Evaporating Temperature °C	Cooling Capacity W	Power W	Gas Flow Rate kg/h	Efficiency W/W
-30	676	617	15.55	1.1
-25	895	703	20.67	1.27
-20	1149	791	26.67	1.45
-15	1438	883	33.58	1.63
-10	1761	981	41.40	1.8

Test Condition: ASHRAELBP32, Fan/NotControlled/220, Return Gas 32.2°C, Ambient 32.2°C, Liquid 32.2°C. Data are an indication of performance based simulation.

## Operating Envelope



## External Dimensions

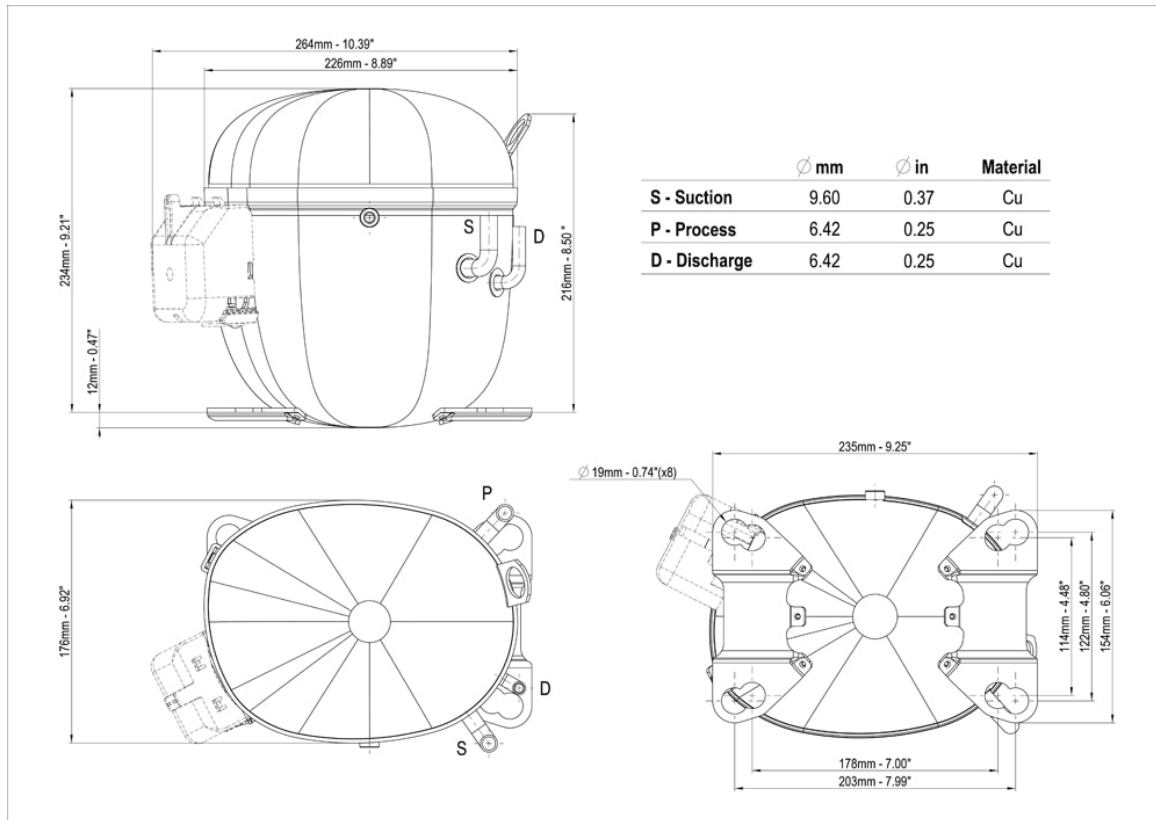

## Wiring Diagram

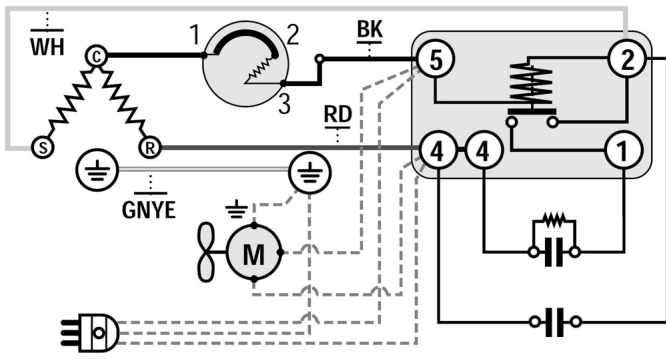

## Assembly Instructions

